

**STANDARD CONSTRUCTION**

**FRAME:**  
6063-T5 EXTRUDED ALUMINUM, 0.125" WALL THICKNESS.  
CAULKING SLOTS PROVIDED.

**BLADES:**  
6063T5 EXTRUDED ALUMINUM, 0.125" WALL THICKNESS.  
45° BLADE ANGLE.  
BLADES ON APPROX. 4" CENTERS.

**RETAINING PLATE:**  
0.125" ALUMINUM SHEET 3003 H-14

**SCREEN:**  
BIRD SCREEN 1/4" x 0.051" OR INSECT SCREEN AVAILABLE.

**FINISH:**  
MILL (STANDARD)  
SKY-WHITE AXALTA 100% POLYESTER POWDER COAT

**OPTIONS:**  
INSECT SCREEN  
BIRD SCREEN (STANDARD)  
0.125" ALUMINUM SLEEVE 3003 H-14 (DOUBLE LEAD TIME)

**SIZES:**  
MAX. SINGLE SECTION 96" X 96"  
MIN. 12"W x 12"H  
UNITS ARE 1/4" UNDERSIZE

JOB NAME:
LOCATION:
ARCHITECT:
ENGINEER:
CONTRACTOR:
<p>CONTACT GRILLE TECH INC. FOR ADDITIONAL INFORMATION OR WITH SPECIAL REQUIREMENTS.</p> <p>5101 NW 36TH AVE MIAMI, FL 33142 PHONE: 305-537-0053 FAX: 305-537-0064</p> <p>WEB: WWW.GRILLETECHINC.COM EMAIL: SALES@GRILLETECHINC.COM</p>

**BLADE**

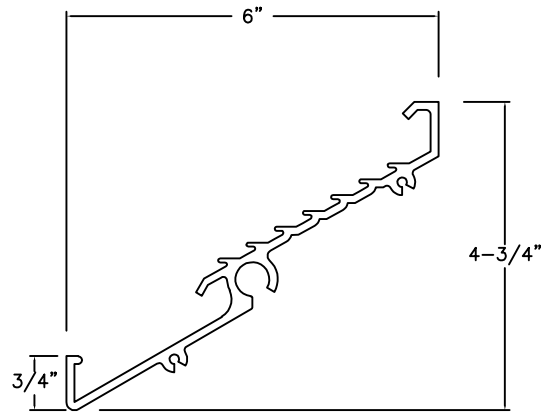

**FLANGED LOUVER JAMB**

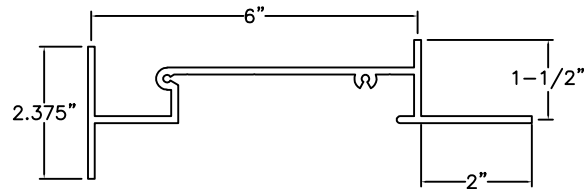

**FLANGED FRAME HEAD AND SILL**

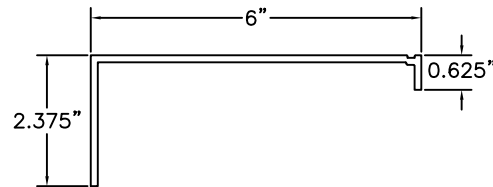

**MODEL WLFDB**  
DRAINABLE BLADE  
OUTSIDE AIR LOUVER  
WITH FLANGE

NOTE: ALL DRAWINGS SUBJECT TO CHANGE WITHOUT PRIOR NOTICE.

DRAWN BY:	MR	DATE:	9/19/17	SCALE:	NOT TO SCALE
CHECKED BY:	IG	DATE:	9/19/17	REVISION:	9/19/17

DRAWING NO.  
**WLFDB**