

**STANDARD CONSTRUCTION**

**MATERIAL:**

COMPLETE MOLDED R6 INSULATED BACK.  
 PERFORATED FACE - 3/16" DIAMETER HOLES ON 1/4" STAGGERED CENTERS.  
 PERIMETER FRAME MADE OF EXTRUDED ALUMINUM.  
 1" EXTRUDED ALUMINUM FRAME.

**FEATURES:**

SUPERIOR SOUND ABSORPTION.  
 LIGHT WEIGHT - EASILY INSTALLED SURFACE MOUNT AND TEE-BAR SYSTEMS.  
 CONDENSATION FREE OPERATION.  
 HINGED FACE PANEL FOR OPTIONAL FILTER REMOVAL.  
 THE MOLDED BACK IS EASILY CUT WITH A POCKET KNIFE AND THE CENTER CONNECTION PROVIDES A VERY UNIFORM, WIDELY DISPERSED, AIR FLOW WITHOUT DOWNDRAFTS.  
 SPACING FOR 1" THICK FILTER (NOT INCLUDED UNLESS SPECIFIED)

**FINISH:**

FACE: SKY-WHITE (STANDARD)

AXALTA SKY-WHITE 100% POLYESTER POWDER COATING GIVES AN ATTRACTIVE BRIGHT WHITE FINISH AND PROVIDES ADDITIONAL PROTECTION FROM AGING AND WEAR.

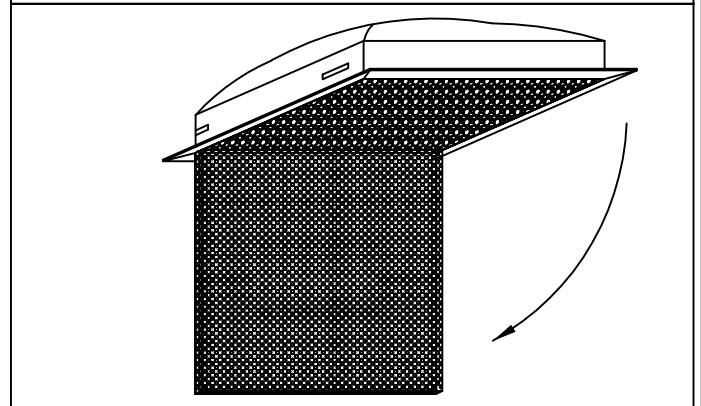
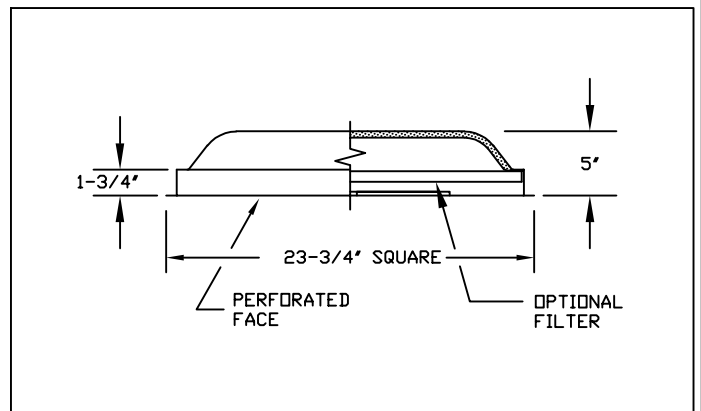
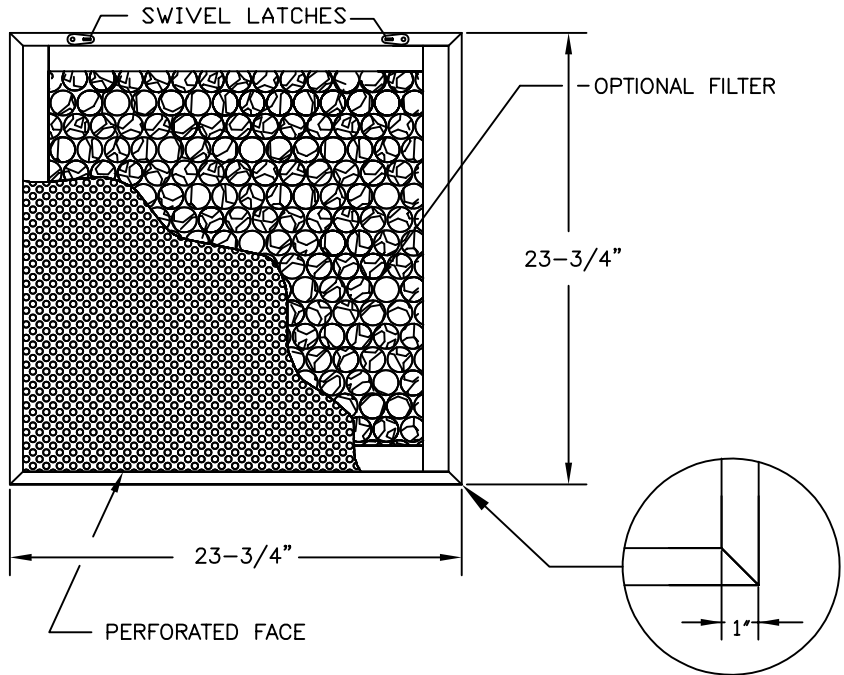

JOB NAME:
LOCATION:
ARCHITECT:
ENGINEER:
CONTRACTOR:
CONTACT GRILLE TECH INC. FOR ADDITIONAL INFORMATION OR WITH SPECIAL REQUIREMENTS.
5101 NW 36TH AVE MIAMI, FL 33142 PHONE: 305-537-0053 FAX: 305-537-0064
WEB: WWW.GRILLETECHINC.COM EMAIL: SALES@GRILLETECHINC.COM

**MODEL PRF-2**

PERFORATED FACE CEILING RETURN  
 R-6 MOLDED BACK AND OPTIONAL FILTER

NOTE: ALL DRAWINGS SUBJECT TO CHANGE WITHOUT PRIOR NOTICE.

DRAWN BY: MR	DATE: 6/21/17	SCALE: NOT TO SCALE
CHECKED BY: IG	DATE: 6/30/17	REVISION: 6/21/17

DRAWING NO. PRF2
------------------