

STANDARD CONSTRUCTION

MATERIAL:
ALL STEEL CONSTRUCTION ON VOLUME CONTROL DAMPER.

FEATURES:
STANDARD SCREWDRIVER CAN BE USED FOR VERTICAL OPERATOR
HEX HEAD SCREWDRIVER CAN ALSO BE USED THROUGH DIFFUSER COLLAR

FINISH:
MILL FINISH

SIZES:
AVAILABLE IN 6", 8", 10", AND 14" DIAMETER

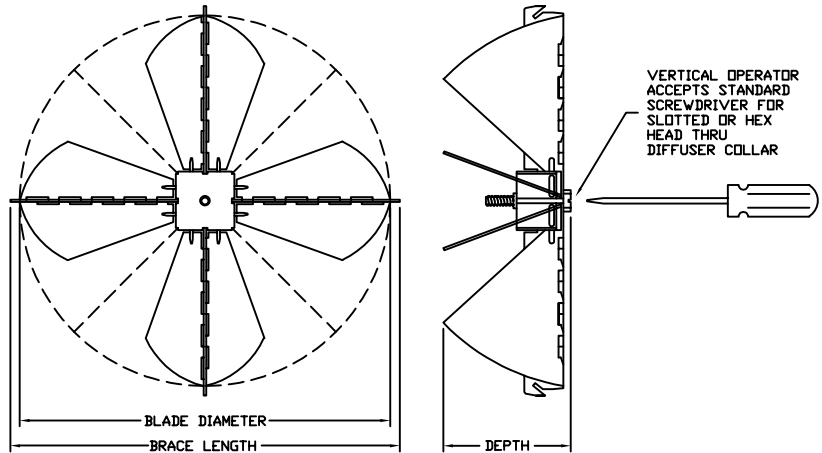

NOMIAL COLLAR SIZES	OVERALL DIMENSIONS		
	BLADE DIAMETER	BRACE LENGTH	DEPTH
6"	5-3/4"	6"	2-38/1"
8"	7-3/4"	8"	3-1/8"
10"	9-3/4"	10"	3-3/4"
12"	11-3/4"	12"	4-1/2"
14"	13-3/4"	14"	5-1/4"

STEP 1.
ALIGN ONE OF THE HOOKS WITH THE DIFFUSER COLLAR AND PUSH IN IT.

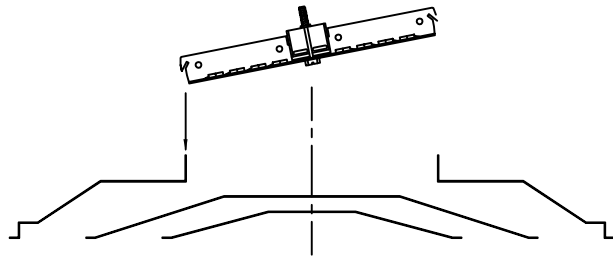

STEP 2.
SNAP-IN THE REST WITH A LIGHT WEIGHT HAMMER.

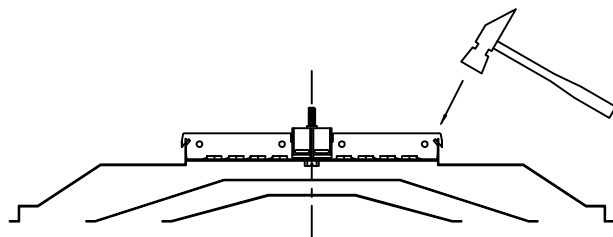

JOB NAME:
LOCATION:
ARCHITECT:
ENGINEER:
CONTRACTOR:
CONTACT GRILLE TECH INC. FOR ADDITIONAL INFORMATION OR WITH SPECIAL REQUIREMENTS.
5101 NW 36TH AVE MIAMI, FL 33142 PHONE: 305-537-0053 FAX: 305-537-0064
WEB: WWW.GRILLETECHINC.COM EMAIL: SALES@GRILLETECHINC.COM

MODEL OBR
OPPOSED BLADE TYPE (RADIAL)
VOLUME CONTROL DAMPER

DRAWN BY: MR	DATE: 8/02/17	SCALE: NOT TO SCALE	DRAWING NO. OBR
CHECKED BY: IG	DATE: 8/31/17	REVISION: 8/02/17	