

STANDARD CONSTRUCTION
MATERIAL:

 BODY AND BLADES: 6063T5 ALUMINUM
EXTRUSION

GASKET:

VINYL GASKET EXTRUSION

GEARS:

2" ROUND GLASS-FILLED FIRE-RETARDANT NYLON

SIZE:

 MINIMUM SIZE: 6" x 4"
MAXIMUM SIZE: 18" x 36"

OPTIONS:

CUSTOM SIZES AVAILABLE.

MOTOR ACTUATOR STYLES:

 POPC: POWER OPEN, POWER CLOSE
(24VAC)(EX. MZD1212-POPC)

 POSC: POWER OPEN (24VAC), SPRING CLOSE
(EX. MZD1408-POSC)

FEATURES:

 FOR USE IN COMPLETE ZONE CONTROL SYSTEMS
OR AS A SIMPLE FLOW SWITCH OF RETURN AIR
BETWEEN LOW AND HIGH RETURNS.

 EXTRUDED ALUMINUM PROVIDES EXCELLENT
CORROSION RESISTANCE AND LONGEVITY.

 BLADE EDGE RUBBER GASKET TO REDUCE LEAKAGE
WHEN DAMPER IS CLOSED.

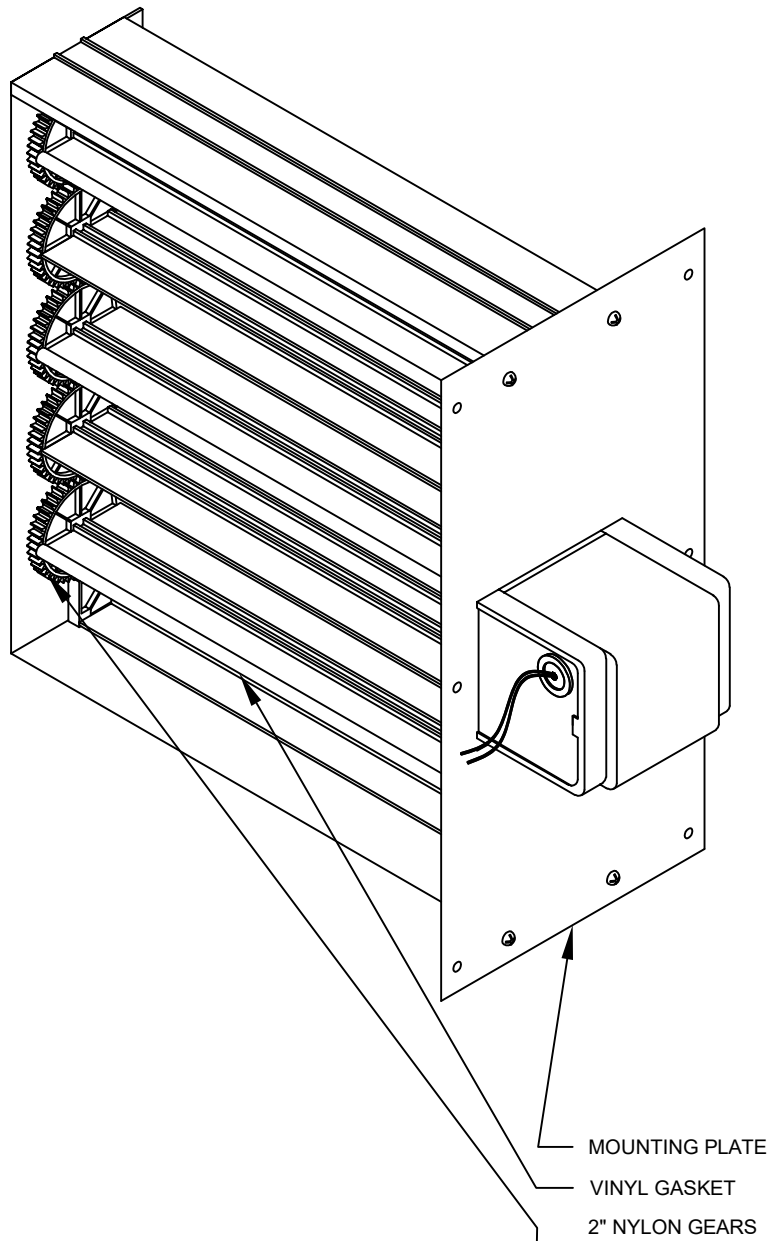
 THE MZD ALLOW FOR RETROFITTING THROUGH AN
OPENING CUT IN THE SIDE OF A DUCT, SECURED
WITH 6 SCREWS THROUGH THE MOUNTING PLATE
TO THE DUCT.

JOB NAME:
LOCATION:
ARCHITECT:
ENGINEER:
CONTRACTOR:
CONTACT GRILLE TECH INC. FOR ADDITIONAL INFORMATION OR WITH SPECIAL REQUIREMENTS.
5101 NW 36TH AVE MIAMI, FL 33142 PHONE: 305-537-0053 FAX: 305-537-0064
WEB: WWW.GRILLETECHINC.COM EMAIL: SALES@GRILLETECHINC.COM

MZD

Motorized Zone Damper, Rectangular

DRAWN BY: MR	DATE: 8/02/17	SCALE: NOT TO SCALE	DRAWING NO.:
CHECKED BY: IV	DATE: 8/31/17	REVISION: 8/02/17	MZD