

STANDARD CONSTRUCTION
FRAME:

6063T5 EXTRUDED ALUMINUM.
 STEEL PATTERN CONTROLLERS.
 FRAME TYPE A: SURFACE MOUNTING (SCREW HOLES).
 FRAME TYPE B: DUCT MOUNTING (NO SCREW HOLES).

BLADES:

STEEL PATTERN CONTROLLERS CHANGE DIRECTION AND VOLUME OF AIRFLOW.

FINISH:

PATTERN CONTROLLER: BLACK POWDER COAT (STANDARD)
 DIFFUSER FACE: SKY-WHITE

AXALTA 100% POLYESTER POWDER COATING GIVES AN ATTRACTIVE BRIGHT WHITE FINISH AND PROVIDES ADDITIONAL PROTECTION FROM AGING AND WEAR.

OPTIONS:

MODELS LPB, LPBR4 AND LPBR6 PLENUMS ARE AVAILABLE IN: 24", 36", 48", AND 60" NOMINAL LENGTHS UP TO 4 SLOTS .
 MULTIPLE SECTIONS AVAILABLE WITH OPEN END OPTION.

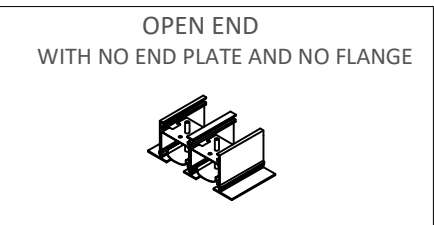
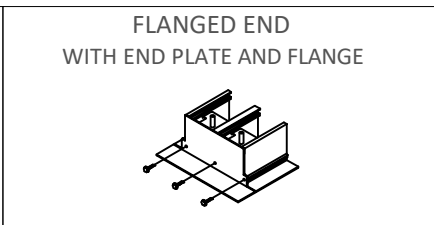
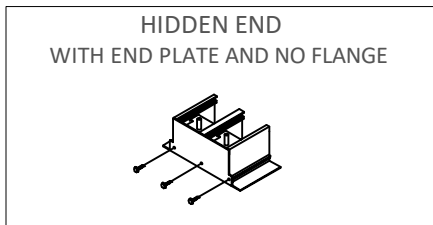
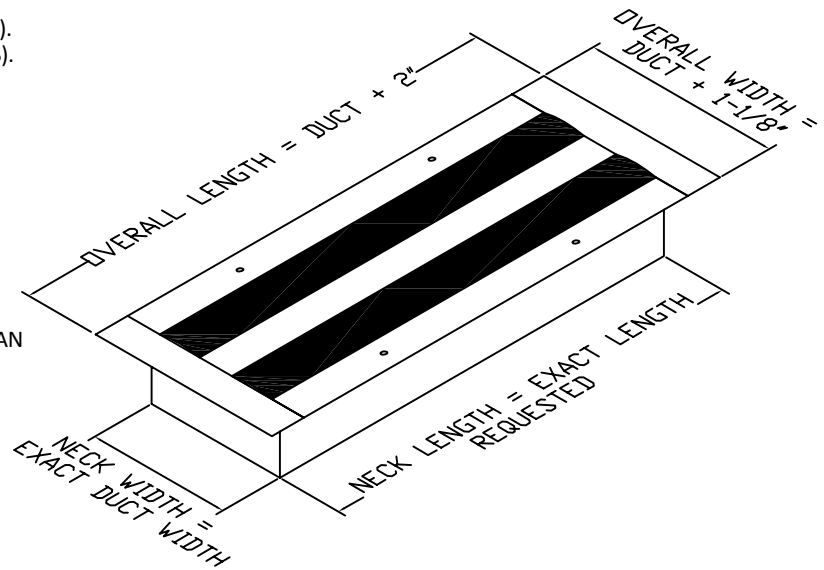
END CONFIGURATIONS

Open/Open		Open/Hidden		Hidden/Hidden		Flanged/Flanged		Open/Flanged		Hidden/Flanged	
C	O	C	O	C	O	C	O	C	O	C	O
D	D	D+1/16"	D+1/16"	D+1/8"	D+1/8"	D-1/4"	D+1 3/4"	D-1/4"	D+3/4"	D-5/16"	D+13/16"

D = Duct Size C = End Cap Position O = Overall Length

JOB NAME:
 LOCATION:
 ARCHITECT:
 ENGINEER:
 CONTRACTOR:

CONTACT GRILLE TECH INC. FOR ADDITIONAL INFORMATION OR WITH SPECIAL REQUIREMENTS.

5101 NW 36TH AVE
 MIAMI, FL 33142
 PHONE: 305-537-0053
 FAX: 305-537-0064

WEB: WWW.GRILLETECHINC.COM
 EMAIL: SALES@GRILLETECHINC.COM

DUCT WIDTH DIMENSION ("DW")

NO. OF SLOTS	LS50/LR50 "S" = 1/2"	LS75/LR75 "S" = 3/4"	LS10/LR10 "S" = 1"
1	1-5/8"	1-7/8"	2-1/8"
2	2-7/8"	3-3/8"	3-7/8"
3	4-1/8"	4-7/8"	5-5/8"
4	5-3/8"	6-3/8"	7-3/8"
5	6-5/8"	7-7/8"	9-1/8"
6	7-7/8"	9-3/8"	10-7/8"
7	9-1/8"	10-7/8"	12-5/8"
8	10-3/8"	12-3/8"	14-3/8"

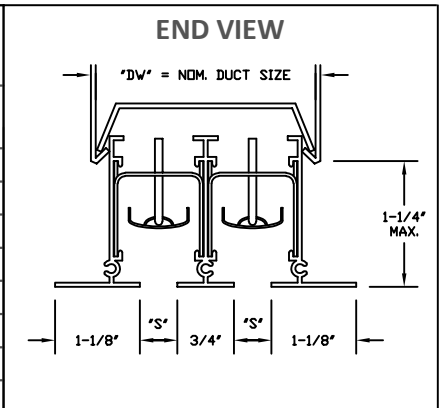
MODEL LS/LR

LINEAR SLOT DIFFUSER
 FRAME TYPE A AND B

DRAWN BY: MR	DATE: 5/19/17	SCALE: NOT TO SCALE	DRAWING NO.
CHECKED BY: IG	DATE: 5/31/17	REVISION: 5/19/17	LS/LR-A/B