**STANDARD CONSTRUCTION**

**MATERIAL:**  
EXTRUDED ALUMINUM FRAME.  
STEEL PATTERN CONTROLLERS.

**FEATURES:**  
PATTERN CONTROLLERS CHANGE DIRECTION AND VOLUME OF AIRFLOW.

**FINISH:**  
PATTERN CONTROLLER: BLACK POWDER COAT  
DIFFUSER FACE: SKY-WHITE POWDER COAT

AXALTA SKY-WHITE 100% POLYESTER POWDER COATING GIVES AN ATTRACTIVE BRIGHT WHITE FINISH AND PROVIDES ADDITIONAL PROTECTION FROM AGING AND WEAR.

**SIZE:**  
12" MIN  
72" MAX

**INTERIOR DUCT HEIGHT**

NO. OF SLOTS	LS10/LR10
1	2"
2	3-7/8"
3	5-3/4"
4	7-1/2"

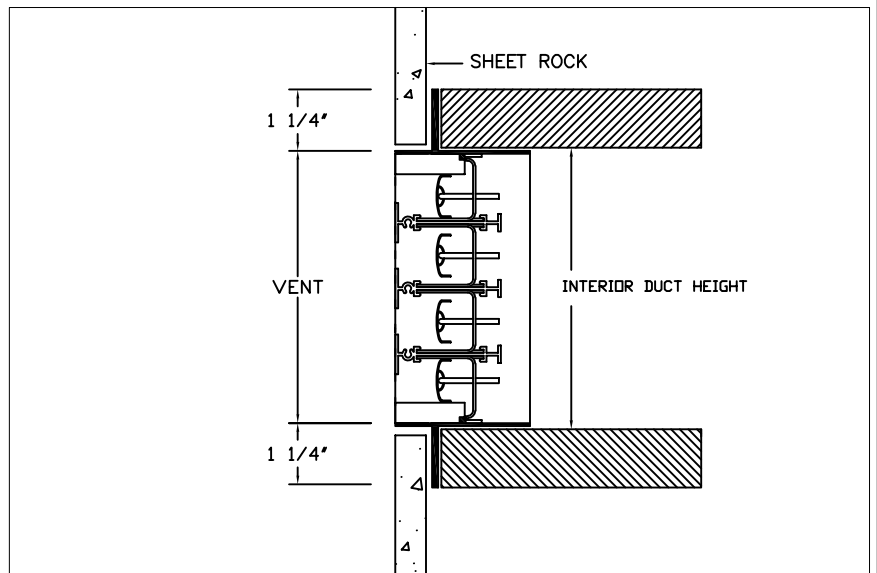
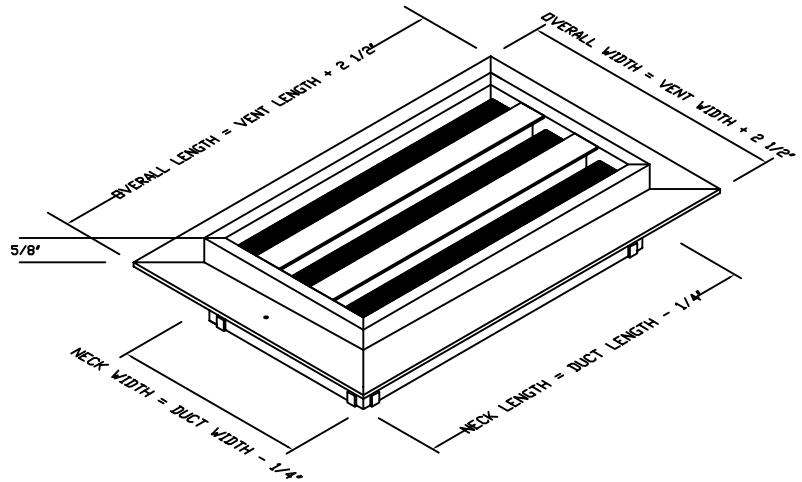
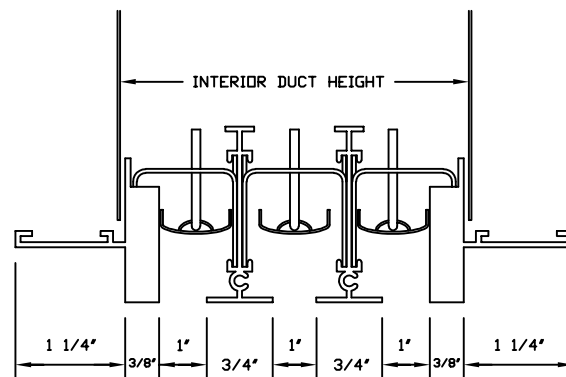
**END VIEW**

JOB NAME:
LOCATION:
ARCHITECT:
ENGINEER:
CONTRACTOR:
<p>CONTACT GRILLE TECH INC. FOR ADDITIONAL INFORMATION OR WITH SPECIAL REQUIREMENTS.</p> <p>5101 NW 36TH AVE MIAMI, FL 33142 PHONE: 305-537-0053 FAX: 305-537-0064</p> <p>WEB: WWW.GRILLETECHINC.COM EMAIL: SALES@GRILLETECHINC.COM</p>

**FRLS**

FRENCH RIVIERA LINEAR SLOT DIFFUSER  
PRODUCT SPECIFICATIONS

NOTE: ALL DRAWINGS SUBJECT TO CHANGE WITHOUT PRIOR NOTICE.

DRAWN BY: MR	DATE: 5/10/17	SCALE: NOT TO SCALE	DRAWING NO. FRLS
CHECKED BY: IG	DATE: 5/31/17	REVISION: 5/10/17	