

STANDARD CONSTRUCTION
FRAME:

6063T5 EXTRUDED ALUMINUM
 NOMINAL WALL THICKNESS OF 0.081"
 UNIVERSAL 1.5" FLANGE

BLADES:

6063T5 EXTRUDED ALUMINUM
 NOMINAL WALL THICKNESS OF 0.081"
 SPACED AT APPROX. 1" CENTERS

FINISH:

MILL ALUMINUM (STANDARD)
 POLYESTER SKY WHITE POWDER COAT (OPTIONAL)

INSECT SCREEN:

1/16" GRAY FIBERGLASS INSECT NETTING

STANDARD VENT SIZES:

8 1/8"W X 2 3/8"H	16 1/2"W X 2 3/8"H
8 1/8"W X 4 3/4"H	16 1/2"W X 4 3/4"H
8 1/8"W X 7 3/4"H	16 1/2"W X 7 3/4"H
12"W X 2 3/8"H	16 1/2"W X 15 3/4"H
12"W X 4 3/4"H	24"W X 2 3/8"H
12"W X 7 3/4"H	24"W X 4 3/4"H
12"W X 11 3/4"H	24"W X 7 3/4"H
15 5/8"W X 7 3/4"H	32"W X 7 3/4"H
15 5/8"W X 15 3/4"H	48"W X 7 3/4"H

FEATURES

HEAVY EXTRUDED ALUMINUM PROVIDES SUPERIOR DURABILITY AND RESISTS CORROSION. CONTINUOUS BLADE DESIGN OFFERS A CLEAN, ATTRACTIVE APPEARANCE. BLADE ANGLE AND OVERLAP LIMITS VISIBILITY INTO THE STRUCTURE. BLADE DEPTH OFFERS GOOD RESISTANCE TO WATER PENETRATION. FLANGED FACE CREATES A GOOD VENT-TO-WALL SEAL AND AN EASY CAULKING SURFACE. OPTIONAL POWDER COATING GIVES AN ATTRACTIVE BRIGHT WHITE FINISH AND PROVIDES ADDITIONAL PROTECTION FROM AGING AND WEAR. FOR BIRD SCREEN, USE PART NUMBER BCV4B.

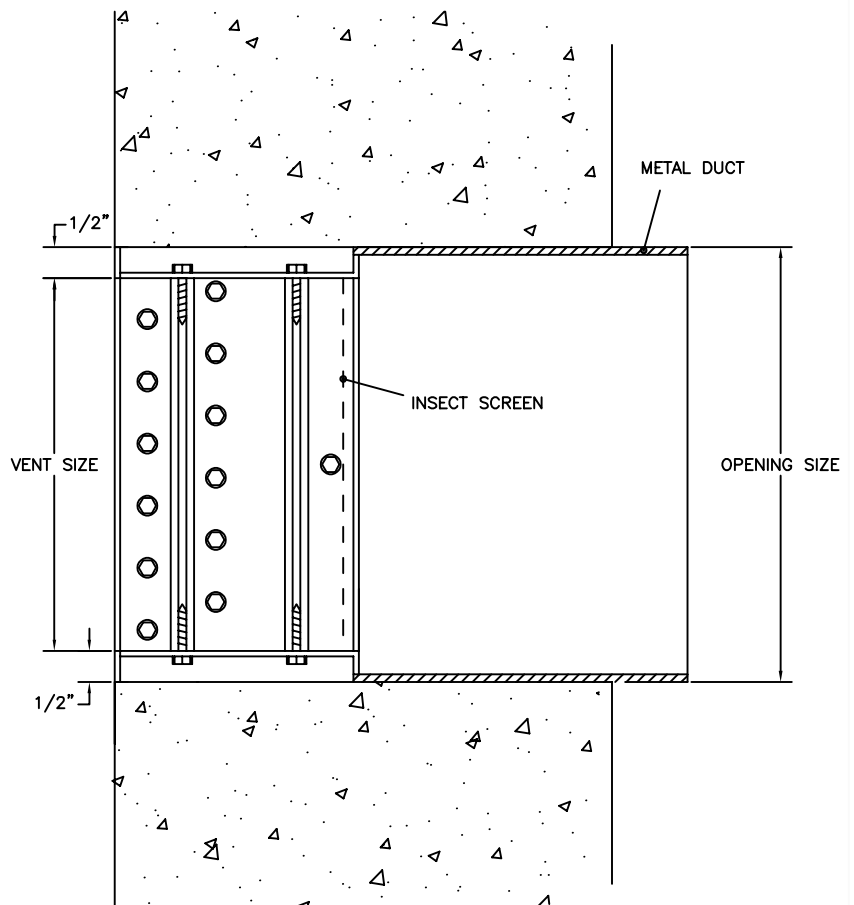
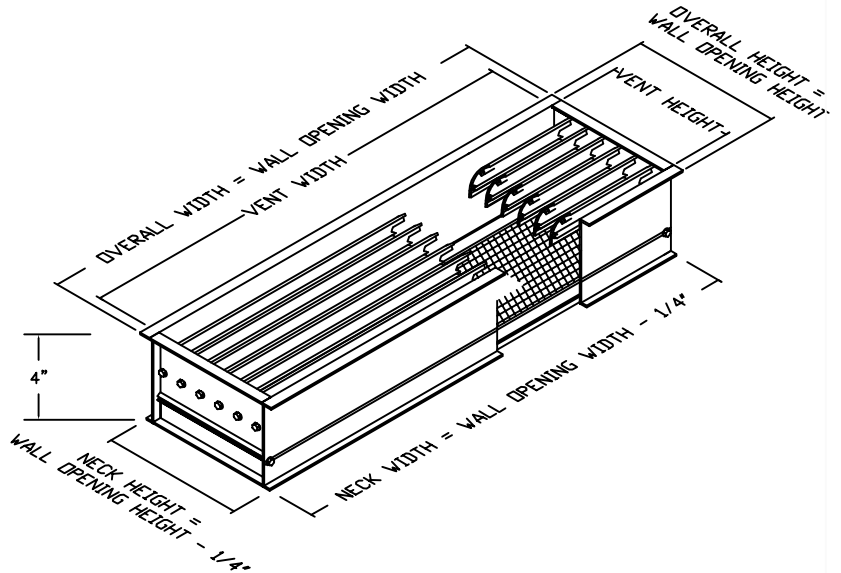

JOB NAME:
LOCATION:
ARCHITECT:
ENGINEER:
CONTRACTOR:
CONTACT GRILLE TECH INC. FOR ADDITIONAL INFORMATION OR WITH SPECIAL REQUIREMENTS.
5101 NW 36TH AVE MIAMI, FL 33142 PHONE: 305-537-0053 FAX: 305-537-0064
WEB: WWW.GRILLETECHINC.COM EMAIL: SALES@GRILLETECHINC.COM

BVC4I

BRICK WALL VENT
 PRODUCT SPECIFICATIONS