

STANDARD CONSTRUCTION
FRAME:

EXTRUDED ALUMINUM.
CORNER CLIPS ASSURE HAIRLINE MITERED CORNERS

ACCESS DOORS:

MADE OF STUCCO EMBOSSED GALV-ALUM STEEL SHEET (AZ50) WITH A PERIMETER ALUMINUM CHANNEL AND 1" R-4.2 FOIL FACED FIBERGLASS BOARD FOR INSULATION AND SOUND ATTENUATION.

FINISH:

SKY-WHITE (STANDARD)

AXALTA SKY-WHITE 100% POLYESTER POWDER COATING GIVES AN ATTRACTIVE BRIGHT WHITE FINISH AND PROVIDES ADDITIONAL PROTECTION FROM AGING AND WEAR.

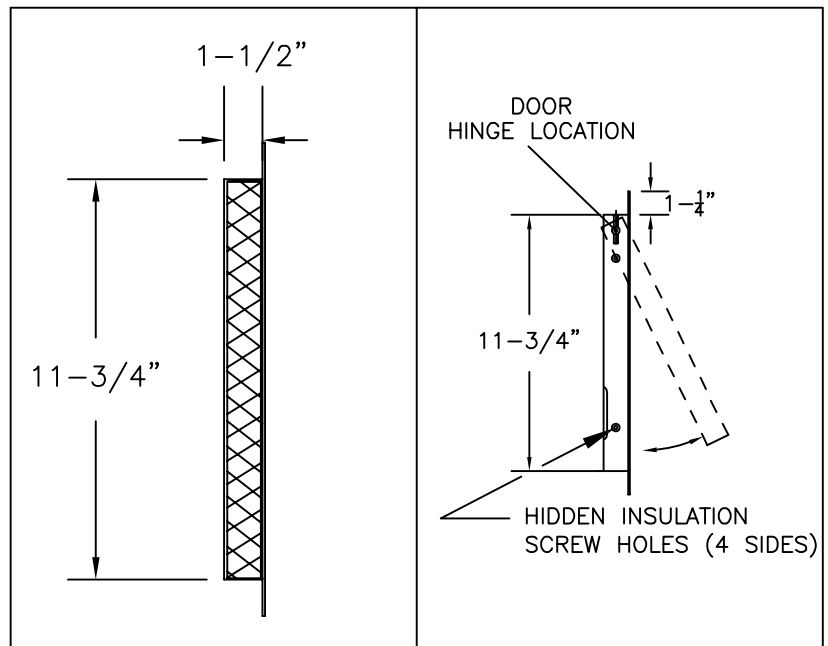
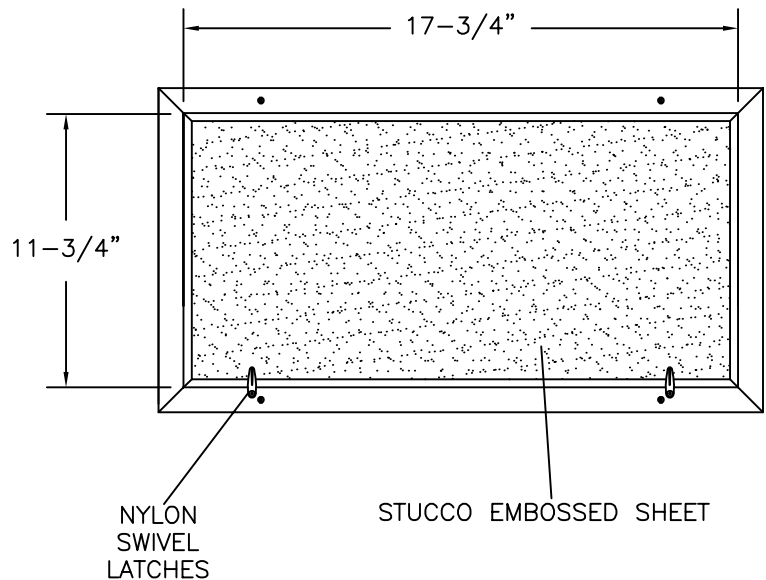
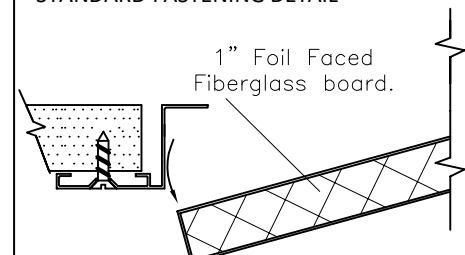
STANDARD FASTENING DETAIL

JOB NAME:
LOCATION:
ARCHITECT:
ENGINEER:
CONTRACTOR:
<p>CONTACT GRILLE TECH INC. FOR ADDITIONAL INFORMATION OR WITH SPECIAL REQUIREMENTS.</p> <p>5101 NW 36TH AVE MIAMI, FL 33142 PHONE: 305-537-0053 FAX: 305-537-0064</p> <p>WEB: WWW.GRILLETECHINC.COM EMAIL: SALES@GRILLETECHINC.COM</p>

DAIKIN APBSVQ3660

ACCESS PANEL DOOR
PRODUCT SPECIFICATIONS

NOTE: ALL DRAWINGS SUBJECT TO CHANGE WITHOUT PRIOR NOTICE.